



# 浙江宝龙机电有限公司

ZHEJIANG BAOLONG M&E CO.,LTD.

## 承认书

# APPROVAL SHEET

版本号: A0

客户信息	客户名称 Customer	
	客户代码 Customer Code	
	项目名称 Project Name	
	料号 Part Number	
	客户承认签章 Customer Approval & Signatures	

宝龙机电	产品名称 Product Name	圆柱振动马达 Cylinder coreless vibration motor				
	产品型号 Product Model	BL4I2V3-X9N				
	设计 Design	马续强 Ma Xuqiang	审核 Check	徐建辉 Xu Jianhui	批准 Approval	兰德福 Lan Defu

地址:中国浙江省乐清市宁康东路 388 号

ADD:No.388, Ningkang East Road, Yueqing City, Zhejiang Province, China

邮政编码/POST CODE: 325600

电话/PHONE: 0577-62578888

传真/FAX: 0577-62574808

网址 1/WEB 1: [HTTP://WWW.BAOLONG.COM](http://www.baolong.com)

网址 2/WEB 2: [HTTP://WWW.VIBRATIONMOTORS.COM](http://www.vibrationmotors.com)

邮箱/E-mail: [BLJSB@BAOLONG.COM](mailto:BLJSB@BAOLONG.COM)

Contact me: [sales@baolong.com](mailto:sales@baolong.com), +86-0577-62572888

产品规格书/Specifications	日期/Date :2018-4-17	
振动电机/Vibration BL4I2V3-X9N	页码/Page: 2 / 15	版本/Version:A0

**- 目录/List -**

封面/Cover	1/15
目录/Contents	2/15
更改记录/Revision History	3/15
1.结构形式/Construction Form	4/15
2.使用条件/Standard Operating Condition	4/15
3.测试条件/Testing Condition	5/15
4.贮存环境/Storage Environment	5/15
5.电气特性/Electrical Characteristics	5/15
6.机械特性/Mechanical Characteristics	7/15
7.环境试验/Environmental Test	8/15
8.寿命试验/Life Test	10/15
9.环保要求/Environment Protections	11/15
10.注意事项/Caution	12/15
11.外形图/Outside View	13/15
12.结构图及物料清单/Structure Drawing & Bom	14/15
13.包装要求/Packaging Requirement	15/15



产品规格书/Specifications	日期/Date :2018-4-17	
振动电机/Vibration BL4I2V3-X9N	页码/Page: 4 / 15	版本/Version:A0

### 1. 结构形式/Construction Form

本规格书适用于浙江宝龙机电有限公司制造的应用于移动电话的振动电机。

This datasheet is stipulated for vibration motor, which is

manufactured by Zhejiang Baolong M&E Co., Ltd. for mobile phone.

NO.	项目/Item	规格/Specifications
1-1	电机结构 Motor construction	φ4 圆柱形无铁芯直流电机 φ4 cylindrical DC coreless motor
1-2	换向片数 Number of phases	3 组换向片 3-phases
1-3	磁极数 Number of magnet poles	两极 (内置磁极型式) 2-poles (Inner magnet type)
1-4	线圈 Coil construction	空心杯式线圈 Columnar coil
1-5	整流技术 Rectifying method	采用高精度电刷和换向器 Precious brush and commutator

### 2. 使用条件/Standard Operating Condition

NO.	项目/Item	规格/Specifications
2-1	额定电压 Rated voltage	DC3.0V
2-2	使用电压范围 Operating voltage range	DC 2.5~3.6V
2-3	旋转方向 Rotating direction	CW / CCW
2-4	使用温度范围 Operating temperature range	-30°C~+70°C

产品规格书/Specifications	日期/Date :2018-4-17	
振动电机/Vibration BL4I2V3-X9N	页码/Page: 5 / 15	版本/Version:A0

### 3.测试条件/Testing Condition

NO.	项目/Item	规格/Specifications
3-1	温度 Temperature	20°C±3
3-2	湿度 Humidity	45% ~85%RH
3-3	电源电压 Supply voltage	直流电源或电池 3.0V DC power supply or battery 3.0V
3-4	电机安放状态 Posture of motor	水平/竖直 Horizontal / Vertical

### 4.贮存环境/Storage Environment

NO.	项目/Item	规格/Specifications
4-1	贮存温度 Storage temp	20°C ± 3
4-2	相对湿度 Relative humidity	65 ± 5% RH

### 5.电气特性/Electrical Characteristic

NO.	项目/Item	单位/Unit	规格/Spec	条件/Condition
5-1	额定转速 Rated speed	rpm	14000±2500	额定电压/Rated voltage: DC 3.0V
5-2	额定电流 Rated current	mA	85Max	额定电压/Rated voltage: DC 3.0V
5-3	启动电流 Starting current	mA	100Max	在额定电压下锁定振动轮, 测电机电流/Measure current at locked counterweight in rated voltage
5-4	启动电压 Starting voltage	V	2.3Max	在额定负荷下电机的任一位置都能转动/The motor can be rotated at any position under rated load

产品规格书/Specifications	日期/Date :2018-4-17	
振动电机/Vibration BL4I2V3-X9N	页码/Page: 6 / 15	版本/Version:A0

5-5	端子阻抗 Terminal resistance	$\Omega$	37 (1 $\pm$ 20%) $\Omega$	正极和负极之间/ Between positive and negative
5-6	绝缘电阻 Insulation resistance	M $\Omega$	10Min	测量机壳和引线之间,测试电 压直流100V。/ Measuring between case and lead wire.Test voltage DC 100V .
5-7	耐电压 Dielectric voltage	mA	1Max	在电机的机壳和引线间施加交 流电 110V, 历时 1 分钟。/ Supply with AC 110V between a lead wire and motor case during 1 minute.

产品规格书/Specifications	日期/Date :2018-4-17	
振动电机/Vibration BL4I2V3-X9N	页码/Page: 7 / 15	版本/Version:A0

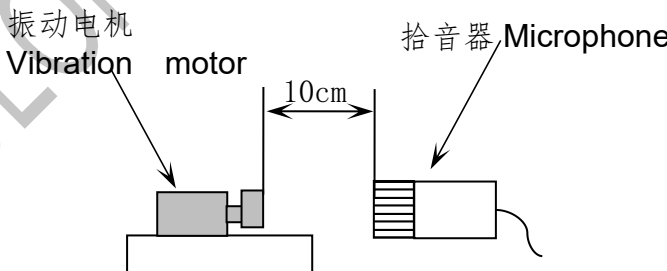
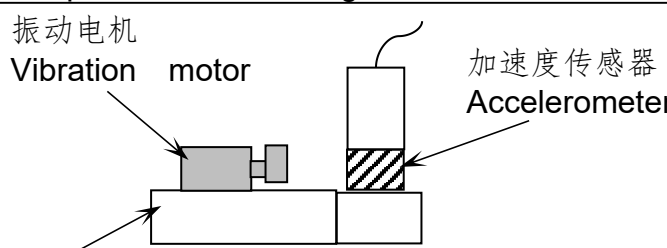
6.机械特性/Mechanical Characteristics				
NO	项目/Item	单位/Unit	规格/Spec	条件/Condition
6-1	外观 Appearance	/	无划痕、 锈蚀、污 迹等不良现象 /No scar, rust, stain and dent	目测/Visual
6-2	尺寸 Size	mm	详见外 形图 /See outline drawing	使用游标卡尺和千分尺测量/ Use vernier caliper and micrometer to measure
6-3	电机重量 Motor Weight	g	0.85±10 %	用天平测量/Use scale
6-4	机械噪音 Mechanical Noise	dB	50 Max	 <p>额定电压/Rated voltage : DC 3.0V 背景噪音/Back ground noise: 30dB Max. 拾音器沿轴向正对电机平面/Microphone faces the plane of motor along the shaft</p>
6-5	振动量 Vibration Strength	Gms	0.8 Min	
		Gp	1.1Min	<p>测试夹具 (100g) Test Fixture (100g) 额定电压/Rated voltage : DC 3.0V</p>

产品规格书/Specifications	日期/Date :2018-4-17	
振动电机/Vibration BL4I2V3-X9N	页码/Page: 8 / 15	版本/Version:A0

7. 环境试验/Environmental Test		
NO	项目/Item	条件/Condition
7-1	高温贮存试验 High temperature storage test	在 $80\pm 2^{\circ}\text{C}$ 的环境下放置96小时, 然后在常温常湿下恢复2小时后测试。/Exposed at $80\pm 2^{\circ}\text{C}$ for 96hours, then return to normal temperature and humidity for 2 hours before test.
7-2	低温贮存试验 Low temperature storage test	在 $-30\pm 2^{\circ}\text{C}$ 的环境下放置96小时, 然后在常温常湿下恢复2小时后测试。/Exposed at $-30\pm 2^{\circ}\text{C}$ for 96 hours, then return to normal temperature and humidity for 2 hours before test.
7-3	湿热试验 Humidity test	将电机置于 $50\pm 2^{\circ}\text{C}$ 、90~95%R.H.的环境下96小时, 然后在室温下放置2小时, 进行恢复, 而后进行测试。/Expose the motor under the environment of $50\pm 2^{\circ}\text{C}$ , 90~95%R.H. for 96 hours and then return to normal temperature and humidity for 2 hours before test.
7-4	高低温试验 Heat cycle test	<p>确保电机在下图所示的条件下放置 12 个周期, 在室温下恢复 2 小时后, 进行测试。/ Assure the motor be placed under below testing conditions for 12 cycles, and then put the motor at normal temperature and humidity for 2 hours until further test.</p> 
7-5	振动量试验 Vibration test	<p>将电机固定在100g的塑料夹具上, 按以下要求进行试验/Fix the motor on a 100g jig (plastic housing),and then make test according to below requirements:</p> <ol style="list-style-type: none"> <li>1)振频范围/Vibration frequency range:10-55Hz</li> <li>2)全振幅/Total amplitude:1.5mm</li> <li>3)振频变化/Sweep ratio:10~55~10Hz 约2分钟/approximate 2 min</li> <li>4)振动方向/Direction of vibration:三个垂直方向/Three</li> </ol>



产品规格书/Specifications	日期/Date :2018-4-17	
振动电机/Vibration BL4I2V3-X9N	页码/Page: 9 / 15	版本/Version:A0

		perpendicular directions 5)持续时间/Duration:每个方向10分钟（共30分钟）/ 10 minutes in each direction (30 minutes each)
7-6	跌落试验 Drop test	电机放在大约100g（包括电机）重的物体上自由落下到水泥地板上。/Set the motor on the heavy block about 100g weight（include the motor） and drop the motor onto the concrete floor. 高度/Height: 1.5m 方向/Direction: $\pm X$ , $\pm Y$ , $\pm Z$ 次数/Times: 每一平面下落2次，共计12次。/Two drops per plane for a total of 12 drops.

▶ 判定标准/Judgment standard

①试验后，测试数据必须符合以下规格：

After test, measured data must be satisfied as following specifications;

- 启动电压/Starting voltage: DC 2.0V Max.
- 额定转速/Rated speed: 变化率在初始值的+50%~-30%以内/ Changing rate must be within +50%~-30% of initial value.
- 额定电流/Rated current: 变化率在初始值的+50%~-30%以内。/Changing rate must be within +50%~-30% of initial value.
- 端子阻抗/Terminal resistance: 变化率在初始值的 $\pm 15\%$ 以内。/Changing rate must be within  $\pm 15\%$  of initial value.

②外形结构无异常。/There should be no abnormalities in appearance and structure.

产品规格书/Specifications	日期/Date :2018-4-17	
振动电机/Vibration BL4I2V3-X9N	页码/Page: 10 / 15	版本/Version:A0

### 8.寿命试验/Life Test

NO	项目/Item	条件/Condition
8-1	寿命试验 Life test	<p>在常温、常湿下，将 DC 3.0V 不断地施加在电机的正负极上，按 A 秒开、B 秒关为一个周期，运行 S 个周期（如下图所示）。 /At room temperature in ambient humidity, the DC 3.0V will continue to be applied to the positive and negative electrode, according to A seconds, B seconds off for a cycle, run S cycle (as shown below).</p> <p>模式/mode A=1, B=1, S=200,000</p>

#### ▶ 判定标准/Judgment standard

①试验后，测试数据必须符合以下规格：

After test, measured data must be satisfied as following specifications;

- 启动电压/Starting voltage: DC 2.0V Max.
- 额定转速/Rated speed: 变化率在初始值的+50%~-30%以内/ Changing rate must be within +50%~-30% of initial value.
- 额定电流/Rated current: 变化率在初始值的+50%~-30%以内。/Changing rate must be within +50%~-30% of initial value.
- 噪音/Noise: 电机应能正常启动，无异常机械噪音。/Should not fail in starting, Should not be unusual mechanical noise.

产品规格书/Specifications	日期/Date :2018-4-17	
振动电机/Vibration BL4I2V3-X9N	页码/Page: 11 / 15	版本/Version:A0

### 9.环保要求/Environment Protections

本产品所有零部件符合欧盟RoHS指令(2011/65/EU,(EU)2015/863)/无卤/REACH指令要求，具体环境有害物质管控限制如下/This product conforms to the EU ROHS (2011/65/EU,(EU)2015/863), Halogen-Free and REACH certification, Specific content as follows;

铅及其化合物最大允许含量为1000ppm/Lead and Lead compounds≤1000ppm

镉及其化合物最大允许含量为100ppm/Cadmium and cadmium compounds≤100ppm

汞及其化合物最大允许含量为1000ppm/Mercury and Mercury compounds≤1000ppm

六价铬化物最大允许含量为1000ppm/Hexavalent chromium compounds≤1000ppm

多溴联苯(PBB)最大允许含量为1000ppm/Polybrominated biphenylethers≤1000ppm

多溴联苯醚(PBDE)最大允许含量为1000ppm/Polybrominated diphenylethers≤1000ppm

邻苯二甲酸二异丁酯(DIBP)最大允许含量为1000ppm /DIBP≤1000ppm

邻苯二甲酸二丁酯(DBP)最大允许含量为1000ppm /DBP≤1000ppm

邻苯二甲酸苄酯(BBP)最大允许含量为1000ppm/BBP≤1000ppm

邻苯二甲酸二(2-乙基己基)酯(DEHP)最大允许含量为1000ppm/DEHP≤1000ppm

六溴环十二烷(HBCDD)最大允许含量为1000ppm/HBCDD≤1000ppm

溴Br最大允许含量为900ppm/Br≤900ppm

氯Cl最大允许含量为900ppm/Cl≤900ppm

溴加氯之和最大允许含量 为1500ppm/Br+Cl≤1500ppm

REACH指令按最新法规内容管控执行

包装材料环保管控要求：Pb, Cd, Hg, Cr+6 : 4种物质总和 < 100ppm (其中, Cd < 50ppm)

产品规格书/Specifications	日期/Date :2018-4-17	
振动电机/Vibration BL4I2V3-X9N	页码/Page: 12 / 15	版本/Version:A0

## 10.注意事项/Caution

- (1) 该马达是微型精密产品，在运输过程中不要承受超过0.5 kgf的力，否则会引起外形或性能的变化。/As this motor is small and precise, do not press it over 0.5kgf force or while transportation, otherwise it will cause the transformation of performance or external appearance.
- (2) 请注意马达不要接触到液体性物质（比如：水，酒精等）。/ Please keep the motor away from liquid substance (such as water, alcohol, etc.)
- (3) 不要在高温下长时间放置，否则有可能导致电机的性能下降。/Do not expose the motor to high temperature for long time,it may cause a decline in performance.
- (4) 马达不要在以下环境中使用。/Avoid using the motor in the following environment:
  - 高温和高湿的场所/High temperature and high humidity area.
  - 腐蚀性气体如H<sub>2</sub>S、SO<sub>2</sub>、NO<sub>2</sub>等/Corrosive gas such as H<sub>2</sub>S、SO<sub>2</sub>、NO<sub>2</sub> etc.
- (5) 请不要在靠近磁铁或带有磁场的仪器旁边使用或存放马达。/Please do not operate or store the motor adjacent to magnet or apparatus which has a magnetic field.
- (6) 请注意底盖的表面存在漏磁通量。/Please be careful that there exists a leaking magnetic flux on the surface of bracket.
- (7) 电刷和换向器的相互作用，有可能产生轻微的电噪音。/Due to interaction between brush and commutator, there is a possibility to occur electrical noise slightly.
- (8) 如有任何问题，宝龙和客户双方应共同努力解决。/If any problems occur, both the user and Baolong side shall try to solve the problem together.
- (9) 因测试设备有误差，允许有±5%偏差。/ Due to the measurement equipment error, there is a ± 5 % difference tolerance.
- (10) 马达通过ROHS认证。/This motor pass the system of ROHS certification.

产品规格书/Specifications	日期/Date :2018-4-17	
振动电机/Vibration BL4I2V3-X9N	页码/Page: 13 / 15	版本/Version:A0

### 11.外形图/Outside View

技术要求/skills requirement

1. 额定电压/Rated voltage:DC 3.0V
2. 额定电流/Rated current:85mA Max
3. 额定转速/Rated speed: 14000±2500rpm
4. 启动电压/Starting voltage:2.3V Max
5. 启动电流/Starting current:100mA Max
6. 端子阻抗/Terminal resistance:37 (1±20%) Ω
7. 轴向间隙/Axial clearance:0.3mm Max
8. 电机总长不包括轴向窜动间隙/The total length of the motor does not include the axial movement gap

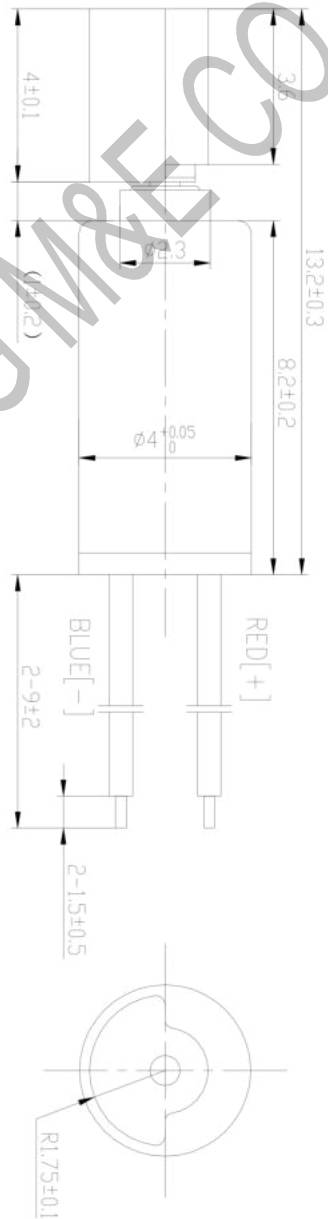

"NG BAOLONG M&E CO.LTD



产品规格书/Specifications	日期/Date :2018-4-17	
振动电机/Vibration BL4I2V3-X9N	页码/Page: 14 / 15	版本/Version:A0

## 12. 结构图及物料清单/Structure Drawing & BOM

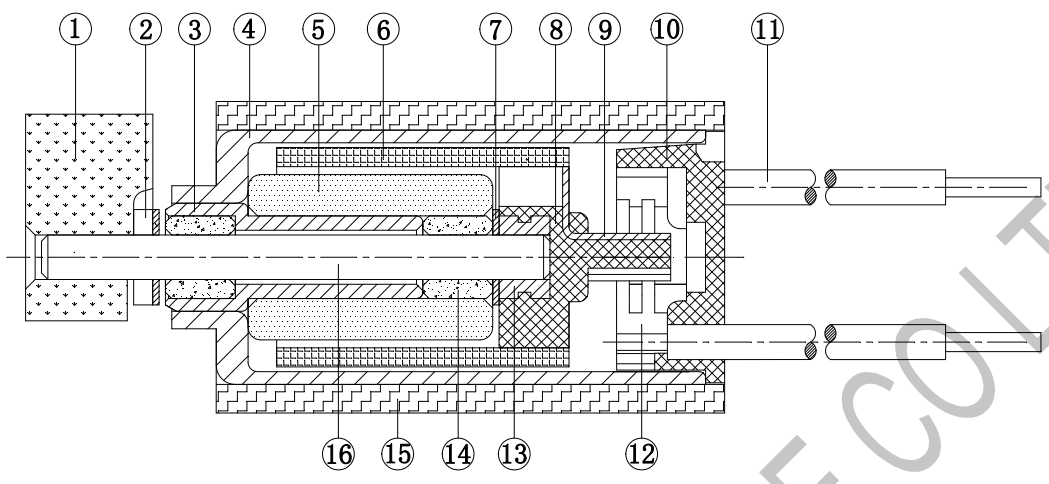

NO.	部件名称/Part name	材料名称/Material name
1	振动轮/weight	钨合金/Tungsten alloy
2	定位片/Lock washer	聚酯薄膜/Polyester film
3	套管/Housing	易切钢/Steel alloy
4	机壳/Case	冷轧钢板/Steel board
5	磁钢/Magnet	钕铁硼/Nd-iron-boron
6	线圈/Coil	铜/Copper
7	垫片/washer	聚酯薄膜/Polyester film
8	塑料/Plastic	PBT
9	换向片/Commutator slice	CDF-2
10	端盖/Top Cover	PBT
11	引线/Power line	AWM3302
12	电刷/Brush	AgPd50/MX215
13	轴套/Bushing ring	铍青铜/Beryllium bronze
14	含油轴承/Bearing	铜粉/Copper powder
15	胶套/Build in sheath	硅橡胶/Silica gel
16	钢轴/Shaft	SUS420J2

产品规格书/Specifications	日期/Date :2018-4-17	
振动电机/Vibration BL4I2V3-X9N	页码/Page: 15 / 15	版本/Version:A0

### 13. 包装要求/Packaging Requirement

- (1) 每个吸塑盒里放100个电机。/100 vibrators in each plastic capsule.
- (2) 每30个吸塑盒上盖一个吸塑盒盖，用胶带捆成一捆。/Every 30 capsules as a group put a plastic cover on the group and wrap it in tape.
- (3) 每2捆按图中的叠放方式放入一个外包箱（440×220×160）。/Every 2 bundle are put into an outer case with a size of（440×220×160） by the ways stipulated as the drawing.
- (4) 数量、生产批号均写在外包装箱上。/Quantity and batch number are written on the surface of the outer case.

